

Advanced belt type mixer that has further evolved the required functions



Satake mixers are combination of Satake's experience and its reliable technology



**Integrate
advanced
mixing
technology**

The multi-S mixer series was born from Satake's cutting-edge mixing technology and commitment to products.

The belt reducer type is a mixer that is a step ahead of the rest, responding precisely to user needs by completely exploring compactness, light-weight, and high efficiency.



Extensive achievements in usage are proof of trust

The Multi S Mixers, born from Satake's many years of experience and novel technology, are available in a wide range of variations from 3.7kW to 30kW (top-mount type and side-mount type models), allowing you to choose the best model that meets your needs. Satake's Multi S Mixers of belt reducer type is the most trusted belt type mixer with an extensive track record of use, born from the eyes of our dedicated engineers.

In addition, it also features a high-efficiency and high-discharge eco-impeller developed by the world's top mixing technology laboratory. We offer products that satisfy both hardware and software requirements.



Top-mount type (S3)

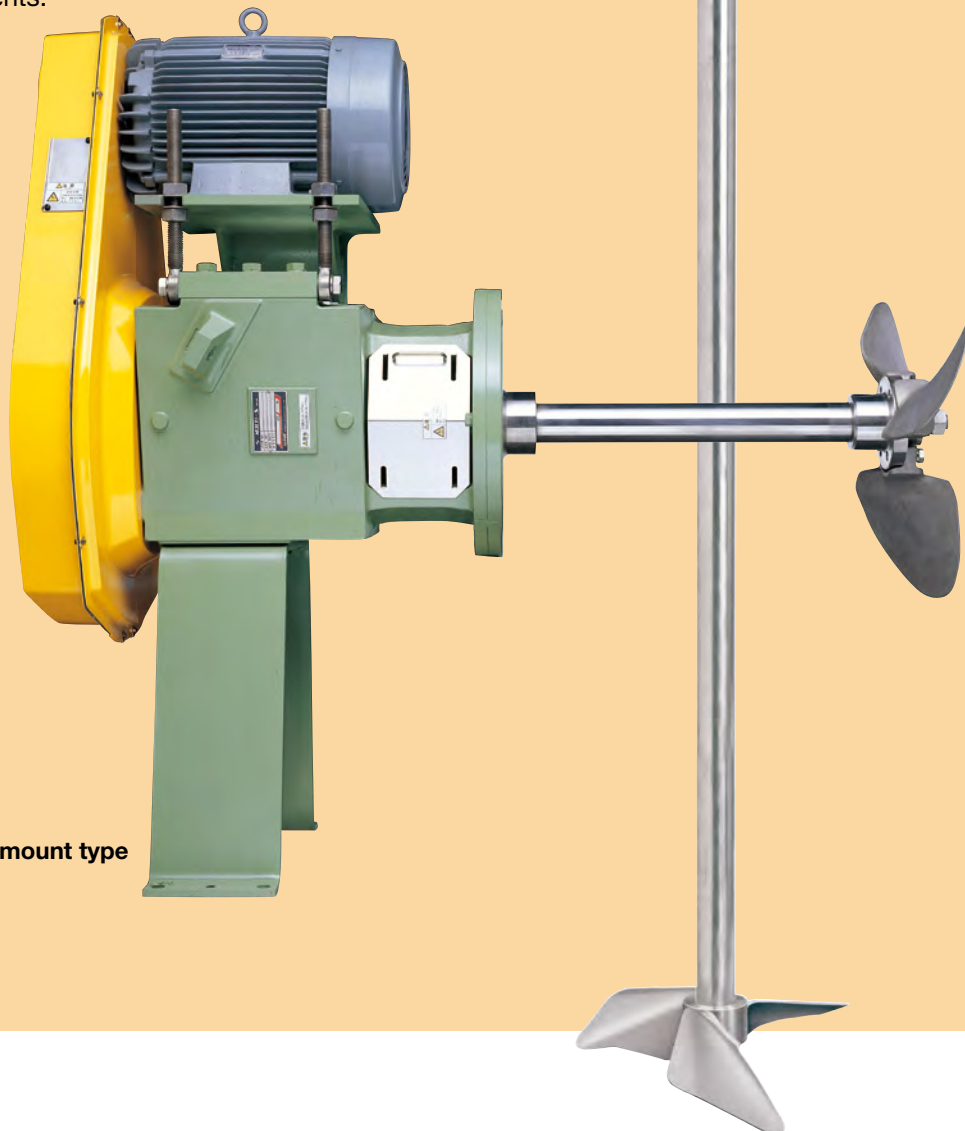

Side-mount type (S4)

SATAKE MULTI SMIXERS

Features

- A simple and compact design of the mixer structure has made handling, maintenance, and inspection easier. The design is based on the user's perspective and respects the user's needs.
- The novel AF100 impeller, which is exclusively designed for the side-mount type, has significantly increased the discharge flow rate.
- The shaft sealing can be selected from a wide range of options depending on the condition of the liquid in the tank. In addition, replaceable gland packings are also available when the tank is full of liquid.
- The belt cover is made of FRP resin (S3 and S4), making it extremely lightweight (applicable to the Fire Service Law). The bottom plate of the belt cover is split into two, making it easy to install and remove.
- The vibration of the motor part is minimized by increasing the rigidity of the motor base.
- The V belt for high-speed drive system is used. It has an excellent life span, oil resistance, heat resistance, and also anti-static. And of course, the operation noise is also quiet.
- The shaft sealing part, which is the important part of a mixer, uses a deep groove ball bearing shield type that is oil-less. The seals are designed to be sufficiently long-lasting to support the output of each series.

Model variations

Impeller speed (min ⁻¹)	Mixing power (kW)							
	3.7	5.5	7.5	11	15	18.5	22	30
350 (4P)		S-3	S-3	S-3	S-4	S-4	S-4	S-5
230 (6P)	S-3	S-3	S-3	S-4	S-4	S-5	S-5	

Examples of main applications

Chemical industry

Uniform mixing of various materials, solids suspension, chemical reaction, dissolution, heat transfer promotion, dispersion, various chemical plants, etc.

Food industry

High precision mixing of food materials, solids suspension and dissolution, heat transfer, etc.

Pharmaceutical industry

High precision mixing of pharmaceutical materials, solids suspension and dissolution, heat transfer, etc.

Petroleum industry

Blending, gas absorption, chemical reaction, extraction, solids suspension, etc.

Paper making industry

Uniform mixing of chest and black liquor, etc.

Fermentation industry

Promotion of fermentation, solution mixing, etc.

Model coding

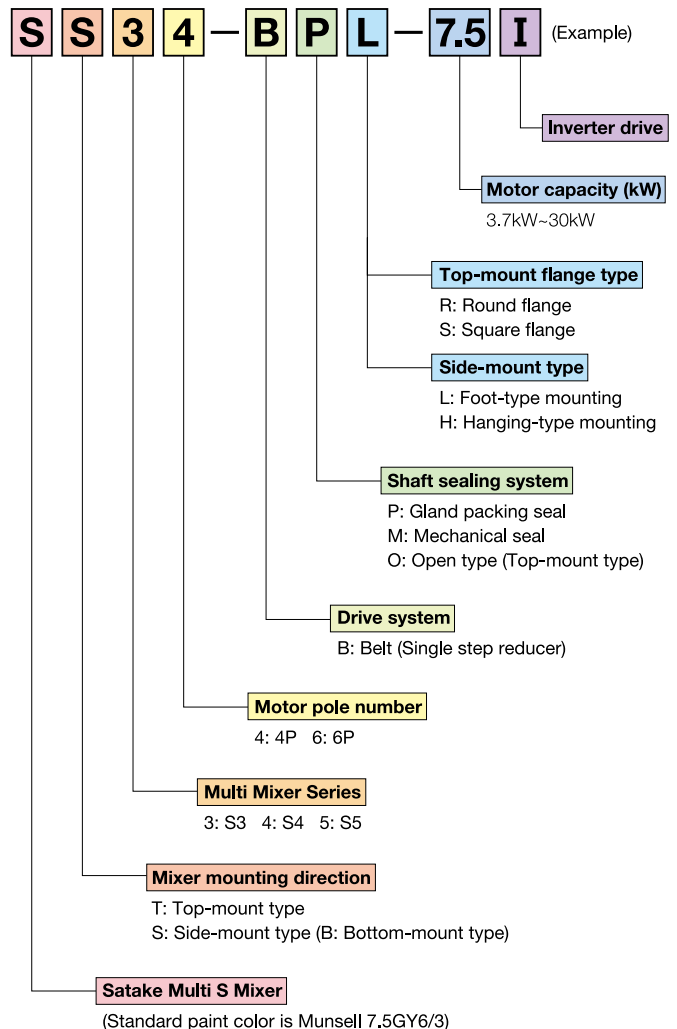

Fat industry

Heating, mixing, extraction, reaction, storage, etc.

Rubber industry

Suspension polymerization, extraction, stripping, crumb slurry tank, rubber dissolution, etc.

Textile industry

Mixing of high-viscosity polymers, dissolution of dyes, mixing of starch paste, etc.

Coal industry

Slurring water, adjusting COM, prevent COM from suspended, preparation tank for gasification, etc.

Water treatment industry

Chemical solution adjustment, wastewater treatment, etc.

Air pollution control

Smoke exhaust desulfurization (gypsum slurry tank), etc.

Utilizing advanced technology – Impeller

Supermix HR100 Impeller (for Top-mount type)

High efficiency and High discharge flow type impeller

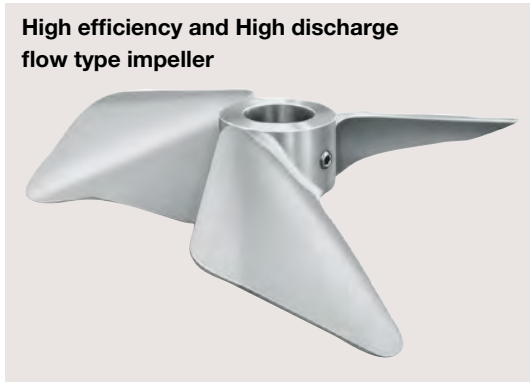

Satake are dedicated in promoting research and development (R&D) of impeller blades based on fluid engineering and impeller blade theory. The impellers born from these R&D are called the Supermix® series, and their superior performance are widely used in various applications.

The Supermix HR100 impeller is designed by considering the shape of blade surface, angle of attack and camber ratio. This impeller is a low shear and energy-saving axial flow type that feature high discharge performance at low power by utilizing a multiple bending structure with twisted-down blade tip to prevent flow separation behind the impeller blade.

Thereby, it is suitable for liquid-liquid mixing, solid-liquid dispersion, and uniform suspension of emulsified microcapsules (latex, etc.), and particles that are easily crushed and light-weight. Additionally, its characteristics can also be demonstrated in combination with other type of impeller by utilizing its excellent axial flow effect.

Flow pattern in a stirred tank using HR100 impeller

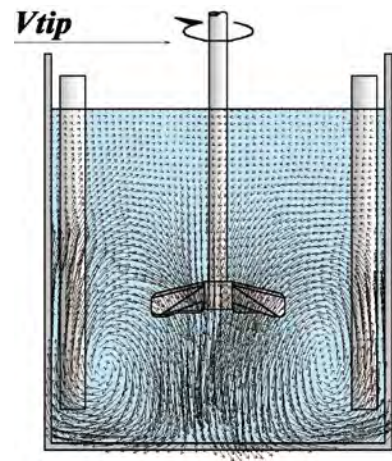
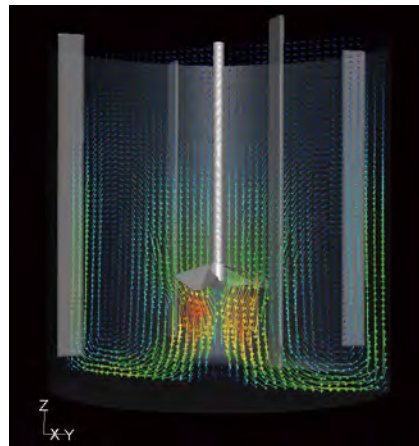

Image processing result using P.T.V.

•The figure above shows the vector image of the actual tank condition captured by the P.T.V. on a CCD camera, processed, and analyzed.



Numerical simulation result using C.F.D.

•High axial flow pattern can be well seen. (Flat discharge flow type shown high discharge impeller blade)

Discharge performance of HR100 impeller

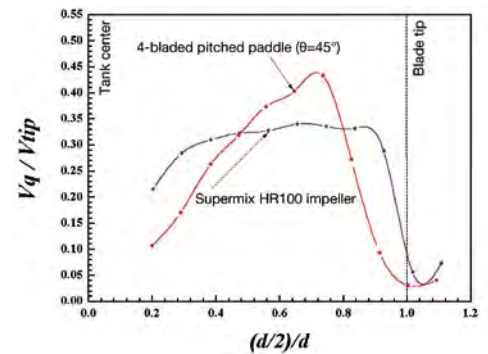

Experimental condition

Tank diameter: D

Impeller diameter: d

Impeller speed: N

Y axis: Discharge flow (Vq)
Impeller tip speed (Vtip)

X axis: Impeller half diameter

D=490mm d/D=0.3

N=300min⁻¹

Comparison on the impeller performance

Impeller type	Ratio of power number	Ratio of discharge flow number	Ratio of discharge flow per unit power	Ratio of required power per unit discharge flow number	Ratio of maximum discharge flow per unit tip velocity
	Np [ratio]	Nqd [ratio]	Nqd/Np ^{1/2} [ratio]	Np/Nqd ³ [ratio]	Vmax/Vtip [ratio]
3-bladed propeller (θ=25°)	Standard value = 1	Standard value = 1	Standard value = 1	Standard value = 1	Standard value = 1
HR100 impeller	1.22	1.37	1.28	0.47	1.10

AF100 Impeller (for Side-mount type)

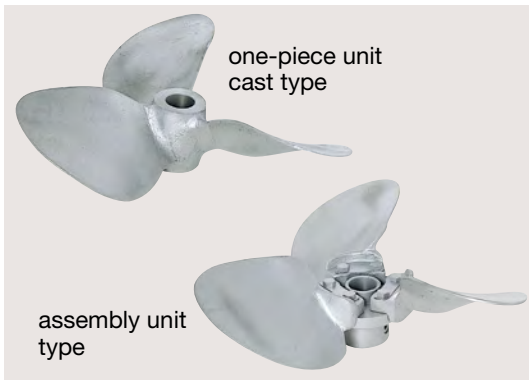

The AF100 impeller features an air-foil cross-sectional design as a result of numerous research and experiments to improve the discharge efficiency of the impeller blades.

Moreover, the impeller blade's plane shape was designed with a skew back to minimize the impact fluctuation associated with the characteristic cavitation observed in side-mount type mixers.

The AF100 impeller is the result of rigorous research by our engineers, which has reduced the impact fluctuation during rotation, thereby significantly improved the discharge efficiency.

This makes the AF100 impeller is an ideal impeller blade for side-mount type mixers.

- The AF100 impeller is made of cast stainless steel.
- The impeller blades with diameter up to 680 mm are cast as a one-piece unit. Meanwhile, the impeller blades with 680 mm or more in diameter are fabricated as an assembled unit.

Mounting position and flow pattern

One of the factors that determines mixing efficiency is the mounting position of a mixer. To determine the mounting position of a mixer, decide the flow pattern that meets the mixing objective by considering the purpose, specific gravity, viscosity, and other properties of the liquid, as well as the mixing ratio, mixing time, etc.

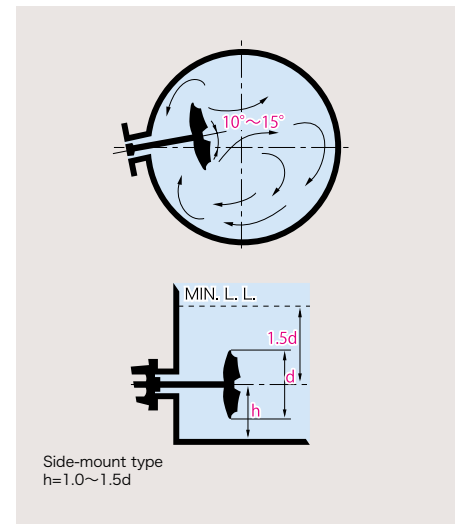
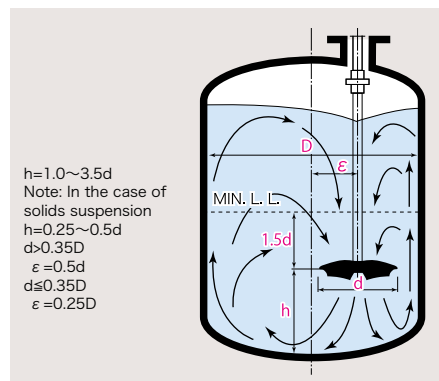
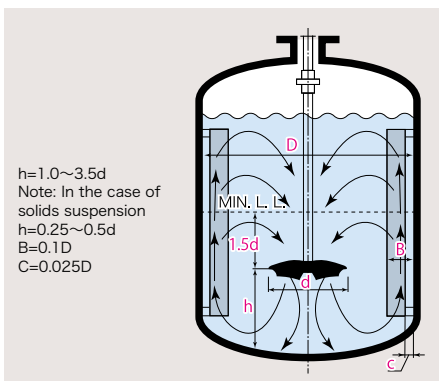

•Center mounting with baffles

The swirling flow is controlled by the baffles, and up-and-down flow becomes dominant. Since the flow becomes turbulent, the mixing effect is enhanced. Normally, two to four baffles are installed equally near the inner wall of the tank and perpendicular to the rotating flow is most suitable.

•Off-center mounting

If the mixer is mounted off-center without baffles inside the tank, it eliminates the concentric flow against the tank, particularly in low viscosity liquids, thereby resulting in good turbulent flow.

•Side-mounting mixer

Generally, similar as to the vertical type, except that the side-mount type is mostly used in deep tanks with medium viscosity or less. For installation in a tank, it is necessary to maintain an off-center angle about 10° as shown in the figure above. This eliminates the need of baffles and also enables to prevent swirling flow.

Regarding the operation that the liquid level passes over impeller position and empty operation

•What is the operation that the liquid level passes over impeller position?

In case of increasing or decreasing the liquid while running the mixer, the bottom impeller is from the stable condition without creating steady suction vortex (at the MIN.L.L. on the drawing) to the fully exposed in air condition (or conversely) within 10 minutes. Failure to do so may cause bending of the shaft. (Please check shaft runout, looseness of bolts, etc.)

•What is empty operation?

A condition in which the bottom impeller is completely exposed in air due to operation through the liquid level. In the case of empty operation, there is no vibration control effect from the liquid, which can lead to shaft bending. Please stop the operation within 10 minutes.

Various variations of shaft sealing systems.

Shaft Sealing Systems - Top-mount type

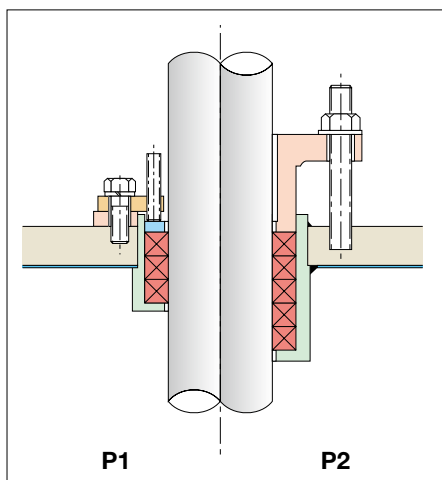

P1

P2

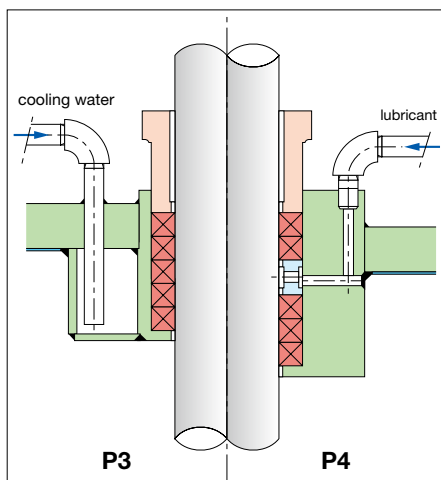

P3

P4

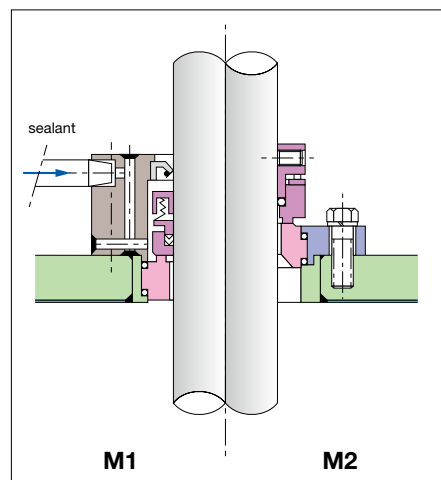

M1

M2

Gland packing seal

P1 type

- Inside tank temperature: 120°C or less
- Inside tank pressure: Atmosphere
- It is not designed for a pressure-tight seal, but it is ideal as a simple seal.

P2 type

- Inside tank temperature: 120°C or less
- Inside tank pressure: 3×10⁻² MPaG (0.3 kgf/cm²G) or less
- It is used for low pressure condition in the tank.

Gland packing seal

P3 type

- Inside tank temperature: Between 121°C and 170°C
- Inside tank pressure: 3×10⁻² MPaG (0.3 kgf/cm²G) or less
- It is ideal for inside tank temperature above 121°C.

P4 type

- Inside tank temperature: 120°C or less
- Inside tank pressure: 0.1 MPaG (1.0 kgf/cm²G) or less
- Inject lubricant periodically in the midsection of the gland packing. Seal the leaking fluid with the packing at the back of the lantern ring and the lubricant with the packing at the front.

Single mechanical seal (For vacuum type mixing tank)

M1 type

- Inside tank temperature: 100°C or less
- Inside tank pressure: F.V.~3×10⁻² MPaG (0.3 kgf/cm²G) or less
- It is generally used for vacuum type mixing tanks that are not tolerant of leaks and demonstrate excellent sealing performance.

Dry mechanical seal

M2 type

- Inside tank temperature: 150°C or less
- Inside tank pressure: F.V.~0.19 MPaG (1.9 kgf/cm²G) or less
- This type of mechanical seal does not require sealant. It is used to prevent sealant from entering the tank, thereby prevent sealant from reacting with the gas or liquid in the tank.



Shaft sealing systems - Side-mount type

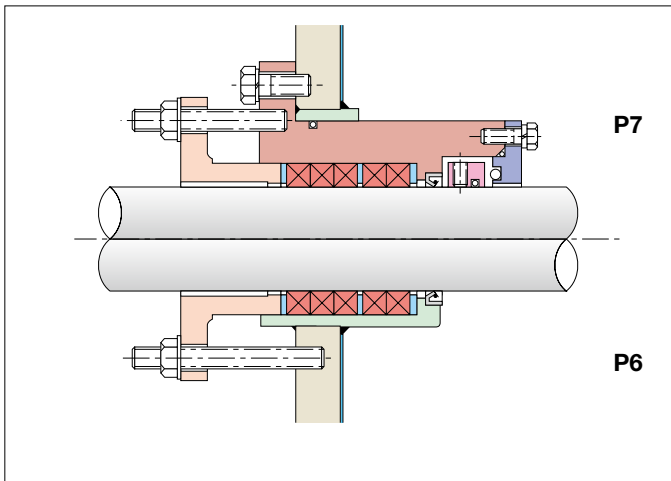

Gland packing seal (temporary seal system)

P7 type

- Inside tank temperature: 120°C or less
- Inside tank pressure: 0.1 MPaG (1.0 kgf/cm²G) or less
- Gland packing can be replaced while tank is full.

Gland packing seal (standard)

P6 type

- Inside tank temperature: 120°C or less
- Inside tank pressure: 0.1 MPaG (1.0 kgf/cm²G) or less

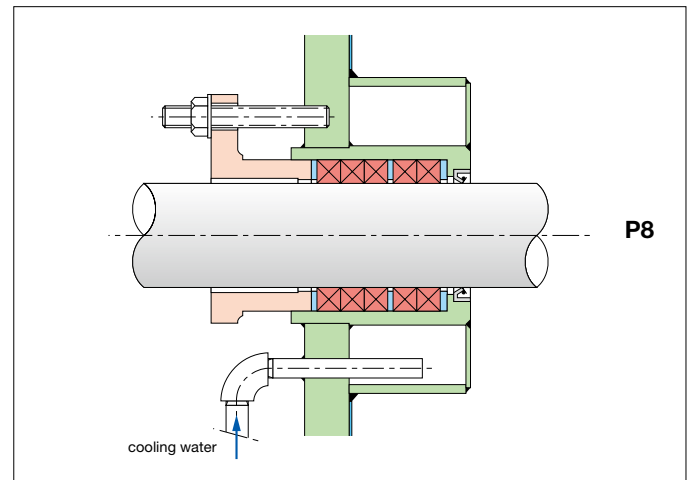

Gland packing seal (forced cooling)

P8 type

- Inside tank temperature: Between 121°C and 170°C
- Inside tank pressure: 0.1 MPaG (1.0 kgf/cm²G) or less
- A jacket is provided at the seal for cooling water to pass through, if the temperature in the tank exceeds 121°C or higher.

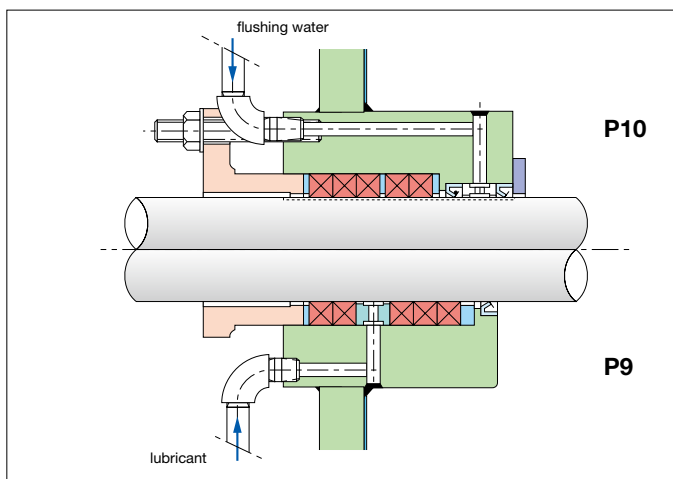

Gland packing seal (for slurry application)

P10 type

- Inside tank temperature: 120°C or less
- Inside tank pressure: 0.1 MPaG (1.0 kgf/cm²G) or less
- Conduct surface hardening treatment on the shaft at the seal area, and inject flushing water (2 to 3l/min) into the tank to prevent slurry liquid from entering the seal area.

Gland packing seal

P9 type

- Inside tank temperature: 120°C or less
- Inside tank pressure: 0.1 MPaG (1.0 kgf/cm²G) or less
- Inject lubricant periodically in the midsection of the gland packing. Seal the leaking fluid with the packing at the back of the lantern ring and the lubricant with the packing at the front.

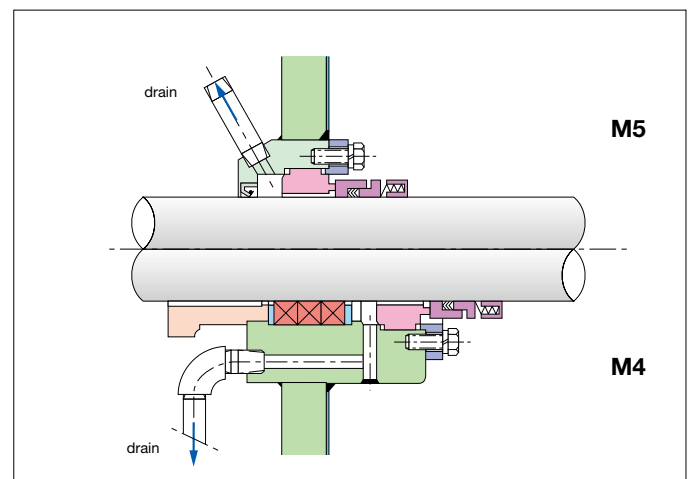

Single mechanical seal

M5 type

- Inside tank temperature: 120°C or less
- Inside tank pressure: 0.3 MPaG (3.0 kgf/cm²G) or less
- It is generally used in applications where leakage is not tolerated and provides excellent sealing performance.

Single mechanical seal + Gland packing

M4 type

- Inside tank temperature: 120°C or less
- Inside tank pressure: 0.3 MPaG (3.0 kgf/cm²G) or less
- The gland packing seals the liquid in the tank when the mechanical seal starts to leak.

We offer double mechanical seal and single mechanical seal replacement type with temporary seal system as non-standard.

Line-up to meet various needs.

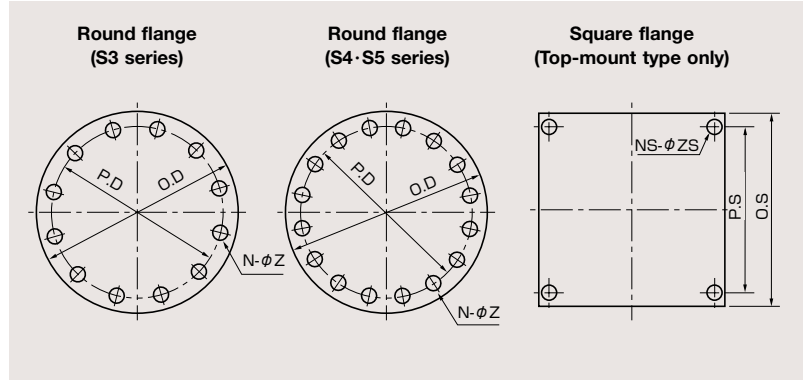
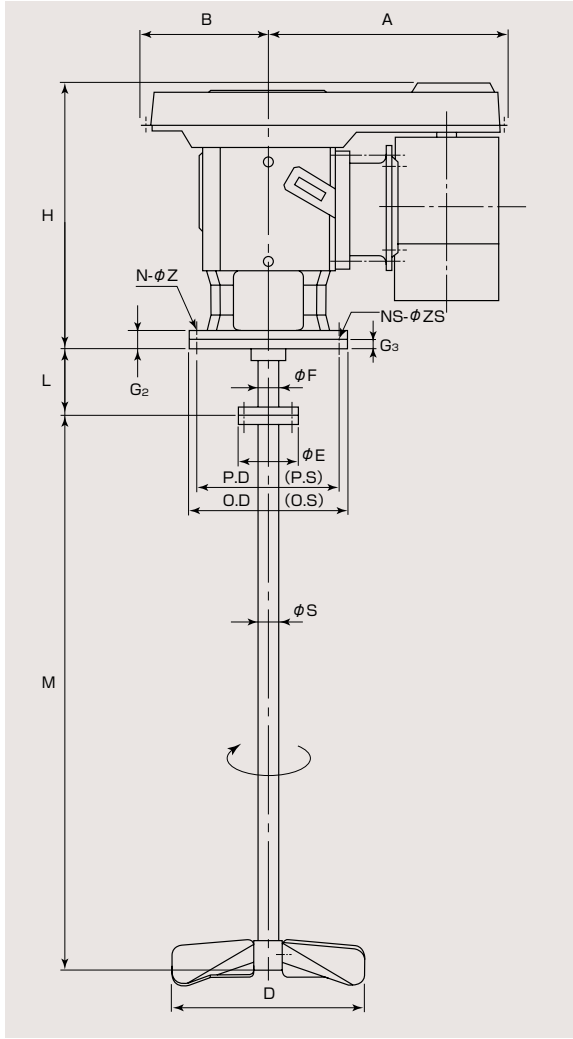

Standard dimensions (Top-mount type)

Unit (mm)

	Impeller speed (min ⁻¹)	Motor power (kW)	O.D	P.D	N-φZ	O.S	P.S	NS-φZS	G ₂	G ₃	φF	φS	φE	L	H	A	B	M	D	Estimated weight (kg)	
																				Main body	Motor
S3 series	350 (4P)	5.5	350	310	12-23	□350	□305	4-24	40	20	60	55	147	200	684	520	286	2,750	520	236	68
		7.5																		246	78
		11																		271	100
	230 (6P)	3.7																		239	68
		5.5																		254	77
		7.5																		282	100
S4 series	350 (4P)	15	445	400	16-25	□445	□395	4-26	46	22	75	70	177	200	856	719	379	2,850	640	498	120
		18.5																		564	185
		22																		569	185
	230 (6P)	11																		477	120
		15																		578	185
		22																		792	215
S5 series	350 (4P)	30	560	510	16-27	□560	□490	4-35	55	26	85	80	207	250	936	845	445	2,400	730	784	215
		18.5																		789	215
	22	792																		215	

* The weight of the mixing shaft and impeller are not included in the estimated weight as shown in the table above.

* The weight of the motor is for the totally-enclosed-fan-cooled motor. Therefore, the motor's weight may vary depending on the motor's brand.

* The M dimension may vary depending on the tank dimension and other factors as well. Therefore, we will select the most suitable length of mixing shaft for you.

* The D dimension may vary depending on the mixing purpose, mixing volume, mixing properties, etc. Therefore, we will select the most suitable impeller diameter for you.

* The G₂ and G₃ dimensions are for round flange and square flange, respectively.

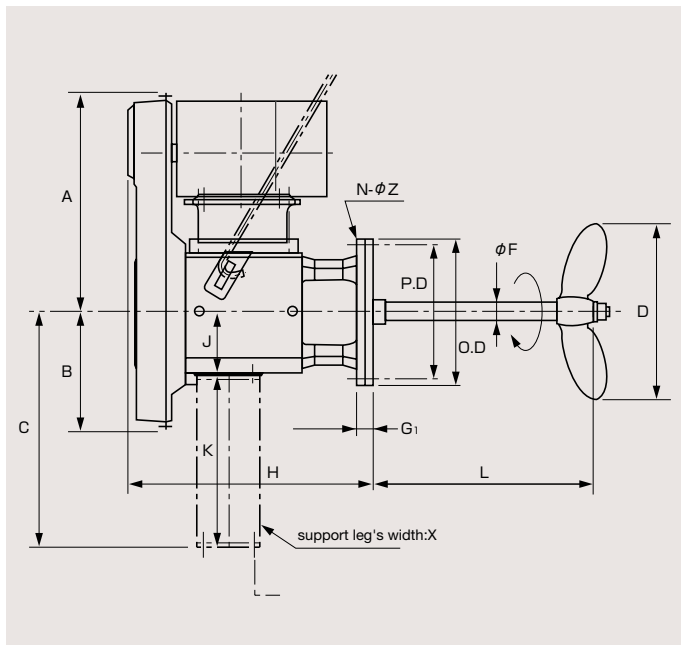

X: S3 series 480mm · S4 series 600mm · S5 series 725mm

Nozzle dimensions for side-mount type mixer

Kindly refer to the table below when installing the side-mount mixer to a steel tank. Also, if the mixing tank is thin and insufficient strength, it is required to reinforce it with support legs or hanger bars.

Unit (mm)												
Series No.	Nozzle size	A	B	C	D	E	F	G	H	J	t	Z
S3	225 ^A	350	310	241.8	50	9.0	750	9	120	22	12	23
S4	300 ^A	445	400	318.5	55	10.3	950	12	150	24	16	25
S5	400 ^A	560	510	406.4	70	12.7	1,200	12	180	28	19	27

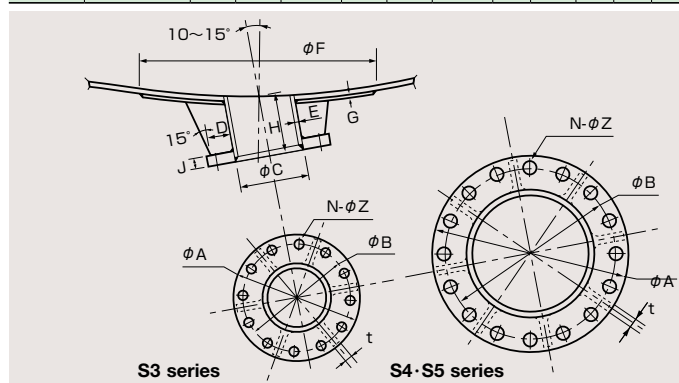

Standard dimensions (Side-mount type)

Unit (mm)

	Impeller speed (min ⁻¹)	Motor power (kW)	O.D	P.D	N-φ Z	G ₁	φ F	L	H	A	B	C	J	K	D	Estimated weight (kg)	
																Main body	Motor
S3 series	350 (4P)	5.5	350	310	12-23	44	60	600	684	520	286	(750)	135	615	500	246	68
		7.5													530	256	78
		11													590	281	100
	230 (6P)	3.7													590	249	68
		5.5													650	264	77
		7.5													680	292	100
S4 series	350 (4P)	15	445	400	16-25	50	75	720	856	719	379	(950)	190	760	630	511	120
		18.5													650	577	185
		22													680	582	185
	230 (6P)	11													740	490	120
		15													790	591	185
S5 series	350 (4P)	30	560	510	16-27	60	85	850	936	845	445	(1,100)	240	870	710	806	215
		18.5													830	811	215
	22	860													814	215	

* The weight of support leg is not included in the in the estimated weight as shown in the table above.

* The weight of the motor is for the totally-enclosed-fan-cooled motor. Therefore, the motor's weight may vary depending on the motor's brand.

For inquiries ... We will recommend the most suitable mixer type, if you specify the following items.

1. Tank geometry:

Dimension (Cylindrical tank, Conical tank, etc.)

2. Tank condition:

Open, Tightly close, Normal pressure, Internal pressure, Vacuum, With or without empty operation

3. Liquid property:

Name of liquid, Specific gravity, Viscosity, Operating liquid temperature

4. Solid property:

Name of solid, True density, Apparent density, Solids concentration, Particle size distribution (Mesh)

5. Liquid volume:

Maximum liquid volume, Minimum liquid volume, Liquid volume changing during mixing (increasing or decreasing)

6. Operating condition:

Batch type, Continuous flow in/out type, Liquid volume, Flow rate, Time lag

7. Mixing purpose:

Liquid-liquid mixing, Solid-liquid mixing
Uniform mixing, Blending, Dissolution, Solids suspension, Reaction, Emulsification, Suspension, Crystallization, Heat transfer, Dilution, Distribution, etc. ... To what extent and in what condition do you want to achieve?

8. Mixing time:

Mixing time require for the above mixing purpose, number of times per day

9. Material request for the impeller and mixing shaft:

We are ready to meet any material requirements, including acid-resistant steel, ordinary steel, and even rubber and various synthetic resin lining finishes.

We are constantly committed to improve the quality of our products, thereby the design and specifications of our products may differ from those shown in the catalog. Please understand this in advance.

We are dedicated to manufacture products that satisfy our customers and are safe to use.



SATAKE CHEMICAL EQUIPMENT MFG., LTD.

Tokyo Office and Plant : 66, Niizo, Toda-shi, Saitama 335-0021, Japan
Phone : 81-48-433-8711 Fax : 81-48-433-8541

Osaka Office and Plant : 2-18-8, Toko-cho, Moriguchi-shi, Osaka 570-0035, Japan
Phone : 81-6-6992-0371 Fax : 81-6-6998-4947

Chubu Sales Service Center : 1-21-9, Heiwa, Naka-ku, Nagoya-shi, Aichi 460-0021, Japan
Phone : 81-52-331-6691 Fax : 81-52-331-2162

Mixing Technology Laboratory : 60, Niizo, Toda-shi, Saitama 335-0021, Japan
Phone : 81-48-441-9200 Fax : 81-48-444-1042

(Overseas associated company)

China **Satake (Shanghai) Trading Co., Ltd.**
Room 605, Huaihai Zhonghua Building, 885 Renmin Road, Shanghai 200010 China
Phone : 86-21-6437-7101

Dalian Satake Chemical Equipment Co., Ltd.
No.8 Qingdao Road, Lushun Economic Development Zone, Dalian 116052, China
Phone : 86-411-3936-8689 Fax : 86-411-3936-8690

Korea **Hado Co., Ltd.**
95, Gajaeul-ro, Seo-Gu, Incheon 22830, KOREA
Phone : 82-32-583-6321 Fax : 82-32-583-6329

Taiwan **Kwan-Tai Machinery Co., Ltd.**
25, Ln. 227, Fuxing Rd., Luzhou District, New Taipei City 24744, Taiwan
Phone : 886-2-2281-9166 Fax : 886-2-2282-4946

<https://www.satake.co.jp>
info@satake.co.jp

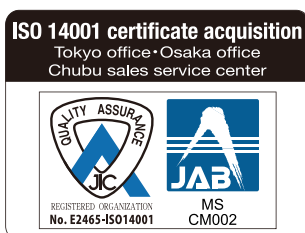

Scope of review:
Development, design, manufacture, repair, and sales management of mixing devices

Satake Multi-S Mixer® and Supermix® are registered trademarks of Satake Chemical Equipment MFG., Ltd.
We are constantly committed to improve the quality of our products, thereby the design and specifications of our products may differ from those shown in the catalog. Please understand this in advance.